



★ KEY FEATURES

➤ Made-to-Measure Miniature Motors

Stradale required custom-designed miniature motors for the shutter and iris module. These bespoke motors were engineered to maintain the necessary torque while being significantly smaller, allowing them to fit seamlessly within the compact design without compromising on performance.

➤ A smaller LED Engine

With an smaller opening diameter, the LED module had to be repositioned closer to the shutter and iris module, decreasing the required distance for the focal length. This reduction in size resulted in a more efficient and compact form factor, with all essential components like the colour mixing systems, animation wheel, and two gobo wheels integrated into the smaller space.

➤ Smaller Gobos

With Stradale's LED module producing a narrower beam, the rotating gobos required a corresponding reduction in image size. The gobo diameter was reduced allowing for a smaller overall gobo. This also enabled a reduction in the thickness of the gobo holders.

Stradale Profile embodies the principle of perfect scalability within Ayrton's Ultimate series, marking the debut of the brand-new 1 Series as its first ultra-compact luminaire. Following in the footsteps of Rivale, it reduces its visual footprint by 15% through meticulous engineering and extreme miniaturization. Every detail has been optimized—streamlining the structure, refining effect modules, and minimizing component size—to push integration to new limits. This unique format necessitated the development of an all-new high-efficiency 330 W LED module, precisely calibrated at 6500 K. Delivering an impressive luminous output of 20,000 lumens, it maintains optimal black body positioning to ensure a perfectly neutral white light.

Lightweight construction plays a crucial role in Stradale Profile's performance. Weighing just 23.5 kg, it sets an unprecedented benchmark for its category. Equipped with a 140 mm front lens, offering a versatile range from 4° to 52°.

➤ A More Compact Form Factor

As part of the Ultimate series, Stradale was designed to achieve a minimum beam angle of 4°. To maintain this while optimizing the smallest possible scalable form factor and ensuring continuous tilt functionality, we determined that a 140mm diameter frontal lens was the ideal solution.

➤ A Lighter, More Efficient Yoke

The smaller and lighter design of Stradale compared to Rivale Profile presented an opportunity to refine the yoke's engineering. Previous fixtures, such as Rivale and Veloce, utilized a yoke constructed from cut, folded, and assembled aluminium sheets. However, Stradale's redesigned yoke is manufactured as a single piece of die-cast aluminium. This innovation results in a structure that is not only more compact but also proportionally lighter.

TECHNICAL SPECIFICATIONS

SOURCE	
Engine	LED Mono Block, Sealed, White
LED Watts	330 W (total fixture use, see Electrical section)
LED Engine Life (L70)	Up to 40,000 hours
LED Refresh Rate	1.2 kHz, 2.4 kHz, 16 kHz, 25 kHz
Dimming	Electronic
Dimming Curves	Square & Linear
Dimming Control Options	Auto on/off dimmer smoothing when Snap effects
Strobe Speed	1-25 Hz Per Second
Strobe Modes	Strobe Effects / Pulse Effects / Random Effects

ELECTRICAL	
Max Power Consumption	630 W
Standby Consumption	146 W @ 20 °C
Voltage Range	100-240 V 50-60 Hz
Current (Max)	2.4 A @ 230 V / 5 A @ 110 V
Inrush (Half Cycle)	110 V: 10.1 A 230 V: 8.9 A
Maximum Current available at the output	12 A
Connector	PowerCON True1 TOP
Power Supply Unit	Active PFC
Contains Battery	N/A

TYPICAL POWER AND CURRENT	
120V , 60Hz	4.55 A, 537 W, PF 0.990
208V, 60Hz	2.59 A, 523 W, PF 0.974
230V, 50Hz	2.36 A, 523 W, PF 0.963
240V, 50Hz	2.28 A, 522 W, PF 0.956

OPTICAL PERFORMANCE	
Lens Size	140 mm (5.52 in)
Zoom Range	4 ° to 52 °
Zoom Ratio	13:1
Gate Size	16 mm

MOVEMENT		
Pan Range	Infinite	
Pan Speed (End to End or range)	180°	100.7 rpm
	360°	161.6 rpm
	EtoE	207.2 rpm
Tilt Range	Infinite	
Tilt Speed (End to End or range)	180°	88.6 rpm
	EtoE	117 rpm
Resolution	8- or 16-bit	
Calibration Time	66 sec	
Position Correction System	Yes / Automatic repositioning	
Follow Spot Modes	Manual & Tracking system	

COLOUR SYSTEM	
Colour System(s)	CMY, CTO, 7 Colour Wheel & 1 Circular multi-colour filter
Control	CMY 16-bit & 8-bit
CTO	2900 K - 6500 K
Variable CTP	TrueColour Enhancer™ filter to 86 CRI
Colour Wheel	One Wheel. Seven Dichroic changeable colours
Colour Wheel Effects	Continuous Rotation

GOBOS	
Indexing Wheel	1
Indexing Gobos	9 (Glass see load below)
Gobo Diameter (Index)	17.2 mm (0.67 in)
Image Diameter (Index)	13 mm (0.51 in)
Static Wheel	1
Static Gobos	10 (Glass see load below)
Gobo Diameter (Static)	25.5 mm (1 in)
Image Diameter (Static)	11 mm (0.43 in)
Gobo Thickness	1.1 mm
Animation Wheel	Yes
Animation Details	Bi-Directional with continuous rotation

TECHNICAL SPECIFICATIONS

PERFORMANCE		
LED engine output (Sphere)	25,000 lm	
Fixture Output (Sphere)	16,500 lm (Fan Mode Auto)	
	18,900 lm (Fan Mode Stage)	
	10,600 lm (Fan Mode Silence)	
	8,000 lm (Fan Mode Super Silence)	
Fixture Output (Goniometer)	13,500 (Fan Mode Auto after derating)	
Field Lumens (Goniometer)	Narrow	9,800 lm
	Middle	13,500 lm
	Wide	13,400 lm
Lumen Per Watt (LPW) Max fixture output / 230 V Typical power	38.5	
CCT	6500	
Δuv	0.0030	
CRI	Ra: 70 (± 2)	
With TrueColour™ Filter	> 70 to 86	
Tm30	Rf: 71 Rg: 94	
TLCI	48	
CQS	69	

IMAGING	
Framing	4 Blade – 4 Plain Full Swipe
Framing Rotation	+/- 90°
Iris	15 Blade - 15% to 100% (Open)
Frost	2 Frost filters: Light 1° & Heavy 5°
Prism	2x (1x 5-Facet Circular, 1x 4-Facet Linear) Indexable, Rotating & Combinable

CONNECTORS	
Power	In/Thru powerCON True 1
DMX	In/Thru 5 Pin XLR
Network	In/Thru RJ45
Wireless	DMX Only

CONTROL	
DMX Control	DMX (USITT DMX-512-A) RDM (ANSI/ESTA E1.20)
Transceiver/Receiver	RS-485 with Opto Isolation
DMX Modes	2 (Standard & Extended)
Channel Count	Mode 1 Std - 44 / Mode 2 Ext - 67
DMX Chart	Scan the QR code on page 5
Network Protocols	ArtNet & sACN
Local Control	Colour LCD Panel 5 Menu Buttons NFC
Stand Alone Mode	Leader/Follower, presets 250
RDM Functions	Yes
Wireless DMX	CRMX TiMo RDM receiver
WiFi Card	Included
USB Port	No

THERMAL	
Max Surface Temperature, steady state, at Ta 40°	90 °C (194 °F)
Max Ambient Temperature (Ta Max)	45 °C (113 °F)
Min Ambient Temperature (Ta Min)	-20 °C (-4 °F)
Total Heat Dissipation (Calculated +/- 10%)	146.5 BTUs p/h 500 W @ 230 V
Minimum distance to illuminated surface	0.5 m (1.64 ft)
Minimum distance to combustible surface	3 m (9.84 ft)
Thermal Protection system	Yes
Cooling modes	See Acoustics
Cooling System	<ul style="list-style-type: none"> Advanced Liquid Cooling. IP68 Self-adjusting variable speed fans for quiet operation.

TECHNICAL SPECIFICATIONS

ACOUSTICS STATIC		
Fan Mode	dBA ¹	NC ²
Auto	43.2 dBA	NA
Stage	47.5 dBA	NA
Silence/Studio	36.2 dBA	NA
Super Silence	32.4 dBA	NA

DYNAMIC		
Mode	dBA ¹	NC ²
Auto	NA	NA
Stage	NA	NA
Silence/Studio	NA	NA
Super Silence	NA	NA

1. Measured @ 1m Static, 31dBA ambient
 2. Noise Criterion
https://www.engineeringtoolbox.com/nc-noise-criterion-d_517.html

ENVIRONMENTAL	
IP Rating	IP65 / IP66
Salt Spray Testing	Pending
Estimated embodied carbon including: <ul style="list-style-type: none"> A1 - Raw materials of fixture and packaging A3 - Product manufacturing 	201.51 kg CO ₂ e/fixture
Recycling options	Packaging widely recyclable. Cardboard is made of recycled pulp ³ .
SIP Optional	Yes

Our Environmental Commitment

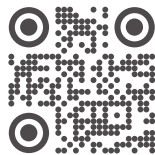

3. Up to 92%

WARRANTY	
Fixture	2 years
LED Engine	5 years

From date of invoice

INSTALLATION	
Orientation	Any
Mounting attachments	<ul style="list-style-type: none"> Fastening bracket system: two Omega ¼ turn brackets designed for use with standard clamps. Mounting points: four ¼ turn locking fittings allowing installation of Omega brackets on luminaire. Safety cable attachment point.
Installation version	Yes IP66

CONSTRUCTION	
Colour	Carbon Black Standard Custom colours on request
Materials	<ul style="list-style-type: none"> Moving-head skeleton made of aluminium and steel metal plates Head in die-cast aluminium Base in die-cast aluminium Heatsinks in aluminium and copper Arms in self-extinguishing fire retardant ABS PC (VO class) Four-side handles for transportation Four heavy-duty feet for better stability

INCLUDED ITEMS	
Manual	1
OMEGA brackets with quarter-turn locks	2
Cables	<ul style="list-style-type: none"> IP65: 1 cable PowerCON True1 TOP to bare end, 1.5m IP66: DMX IN / OUT tails to bare end for IP66 DMX connection Ethernet IN / OUT tails to bare end for IP66 ArtNet™ connection Power tail to bare end for IP66 power connection
Other accessories	N/A

TECHNICAL SPECIFICATIONS

PHYSICAL	
Fixture	
Length	339 mm (13.4 in)
Height	593 mm (23.4 in)
Depth	298 mm (11.7 in)
Weight	23.5 kg (50.7 lb)
IP65	
Length	339 mm (13.4 in)
Height	593 mm (23.4 in)
Depth	298 mm (11.7 in)
Weight	23.5 kg (50.7 lb)
IP66	
Length	339 mm (13.4 in)
Height	593 mm (23.4 in)
Depth	298 mm (11.7 in)
Weight	23.5 kg (50.7 lb)
Shipping Dimensions	
Length	505 mm (19.9 in)
Height	595 mm (23.4 in)
Depth	400 mm (15.7 in)
Weight	31.8 kg (70,1 lb)
In SIP Dimensions	
Length	500 mm (19.7 in)
Height	510 mm (20 in)
Depth	390 mm (15.4 in)
Weight (excl fixture)	4 kg (8.8 lb)

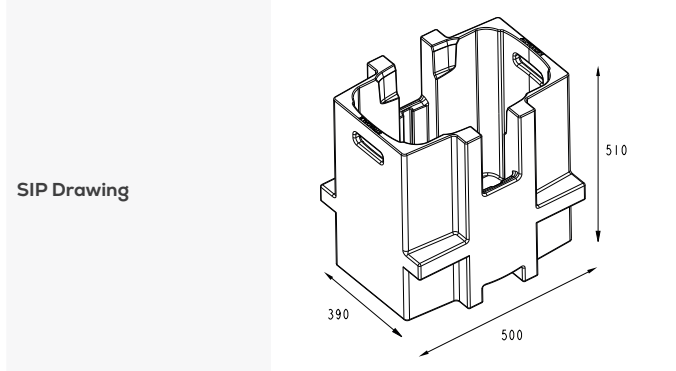

SUPPORTING DOCUMENTS	
Manual	
GDTF Profile	
GMA Profile	
IES File	
DMX Chart	
Software	
Warranty	

COMPLIANCE	
EU (EMC & LVD)	<ul style="list-style-type: none"> EMC Directive 2014/30/EU LVD Directive 2014/35/EU
US (Safety & EMC)	<ul style="list-style-type: none"> UL 1573 FCC Part 15, Subpart B: 2023
Substance Regulations	<ul style="list-style-type: none"> RoHS REACH CP65
Declarations	Scan the QR code above

ORDERING DETAILS	
Stradale Profile IP65	012121
Stradale Profile IP66	012122

ACCESSORIES	
IP Test Kit	048250
Lynx Control	045130
Omega Bracket	GP50501990353

TECHNICAL SPECIFICATIONS

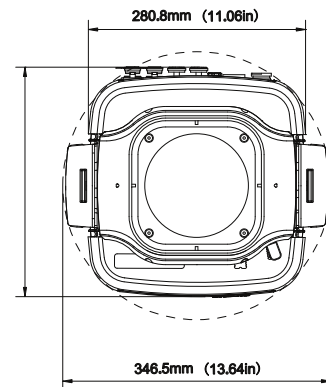
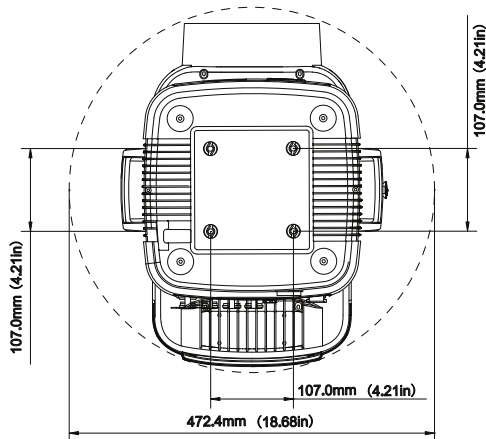
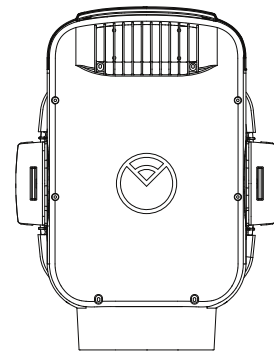
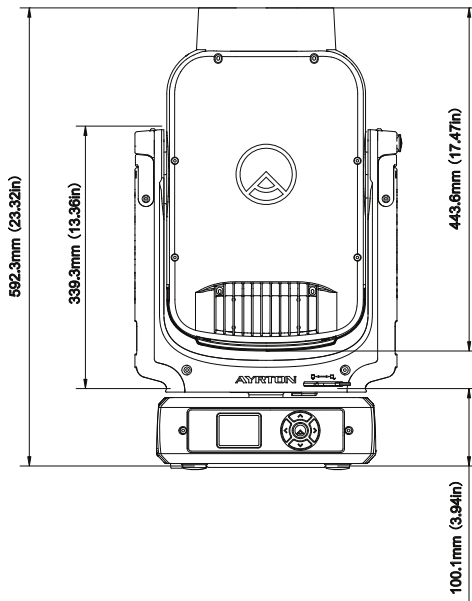
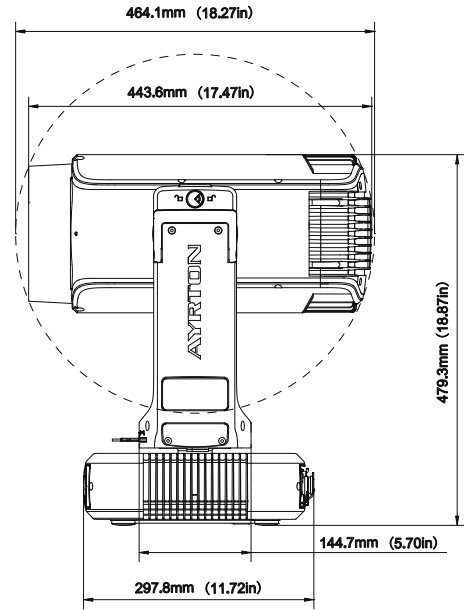
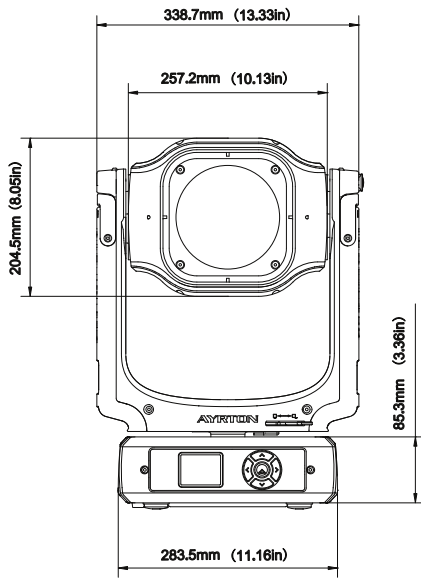

TECHNICAL SPECIFICATIONS

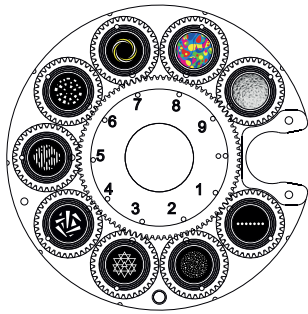

> Dimension/Tolerance/Requirement:

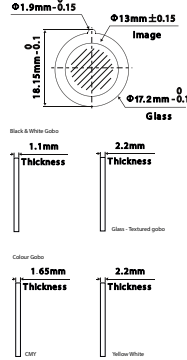

> Temperature Tolerance: 500°C

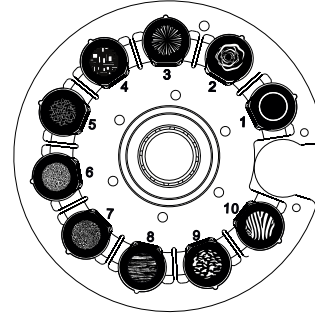

> Dimension/Tolerance/Requirement:

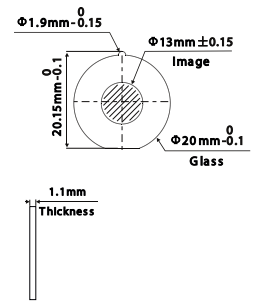

> Temperature Tolerance: 500°C

GOBO WHEEL 1

Rotating Gobo

1	131	Dot Line 7	GPG0500963
2	075	Star Field	GPG0501011
3	018	Nested Triangle	GPG0500965
4	266	Breaking Glass	GPG0500966
5	278	Bread Stix	GPG0500967
6	070	Circle Of Square	GPG0501012
7	112Y	Nested Rings Yellow	GPG0501013
8	042	CMY Liquid Effect	GPG0500970
9	601	Glass Animation	GPG0500921

This side facing LED module

GOBO WHEEL 2

Static Gobo

1	410	Conical Tunnel Effect	GPG0500971
2	049	Smoke Rings	GPG0501014
3	047	Fireworks	GPG0500973
4	066	Abstract Square	GPG0500974
5	081	Iron Filings	GPG0501015
6	041	Lost in the Brain	GPG0501016
4	101	Deep Forest	GPG0501017
8	105	Tree Bark	GPG0501018
9	103	Abstract Speck	GPG0500979
10	097	Zebra Stripes	GPG0500980

This side facing LED module

TECHNICAL SPECIFICATIONS

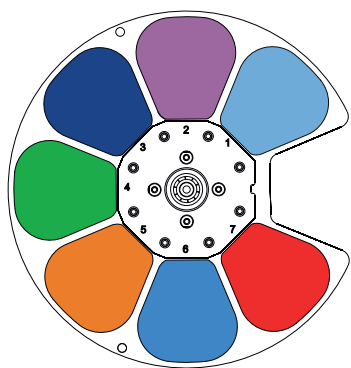

COLOUR WHEEL 1

1	CTB 1/4	GPG0100320
2	Magenta	GPG0100321
3	Congo Blue	GPG0100322
4	Green	GPG0100323
5	Orange	GPG0100324
6	Blue	GPG0100325
7	Red	GPG0100326

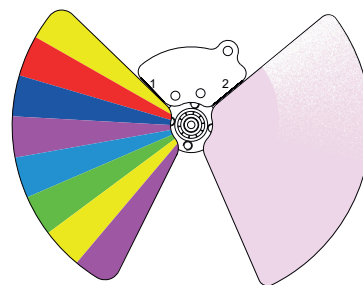

COLOUR WHEEL 2

1	Multi-colour filter	-
2	CTP	-

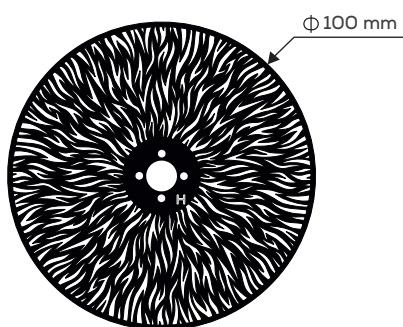

ANIMATION WHEEL

- -

AUTO MODE: PHOTOMETRIC DETAIL

MIN ZOOM

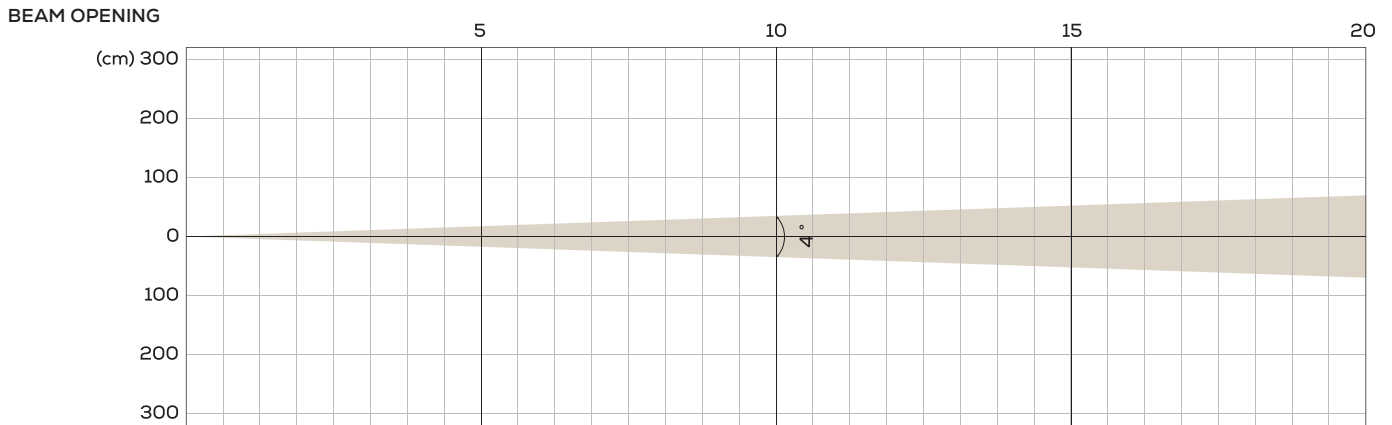

INTENSITY

Distance (m)	5		10		15		20	
	Lux	Diameter	Lux	Diameter	Lux	Diameter	Lux	Diameter
White	98,342	0.35	24,585	0.7	10,927	1.05	6,146	1.4

MIDDLE ZOOM

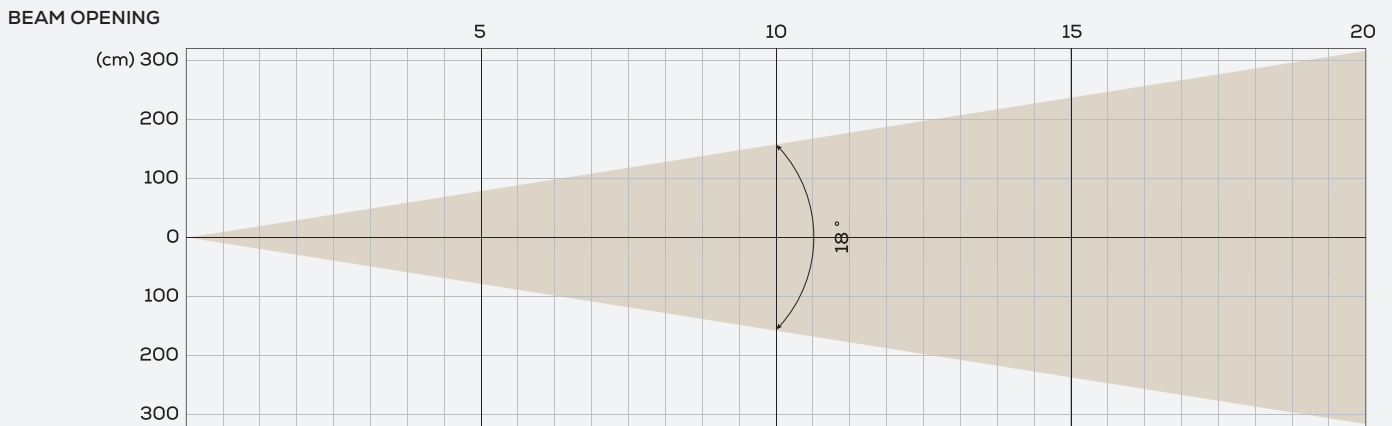

INTENSITY

Distance (m)	5		10		15		20	
	Lux	Diameter	Lux	Diameter	Lux	Diameter	Lux	Diameter
White	7,561	1.58	1,890	3.17	840	4.75	473	6.34

MAX ZOOM

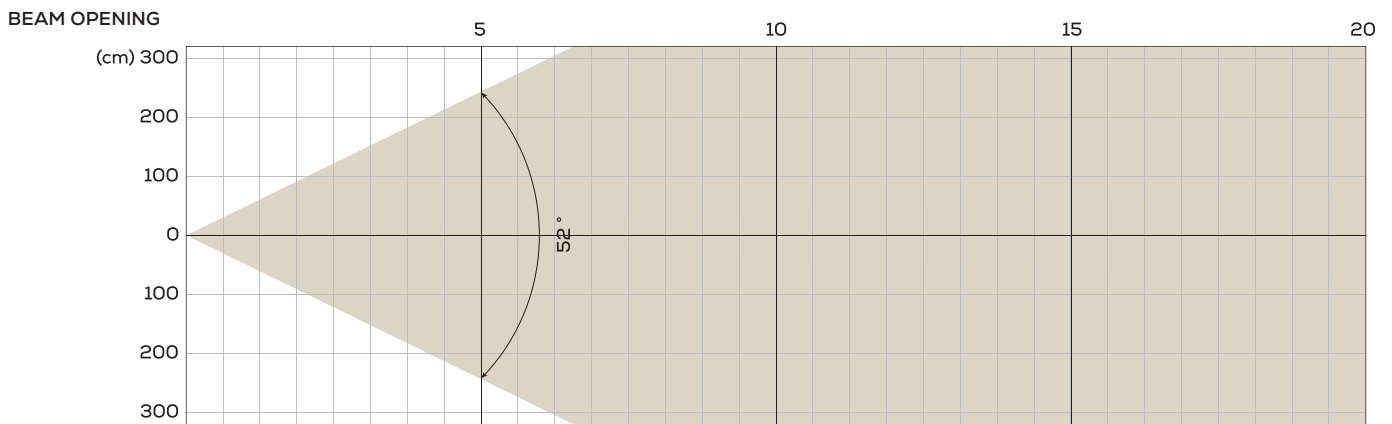

INTENSITY

Distance (m)	5		10		15		20	
	Lux	Diameter	Lux	Diameter	Lux	Diameter	Lux	Diameter
White	930	4.88	232	9.75	103	14.63	58	19.51

STAGE MODE: PHOTOMETRIC DETAIL

MIN ZOOM

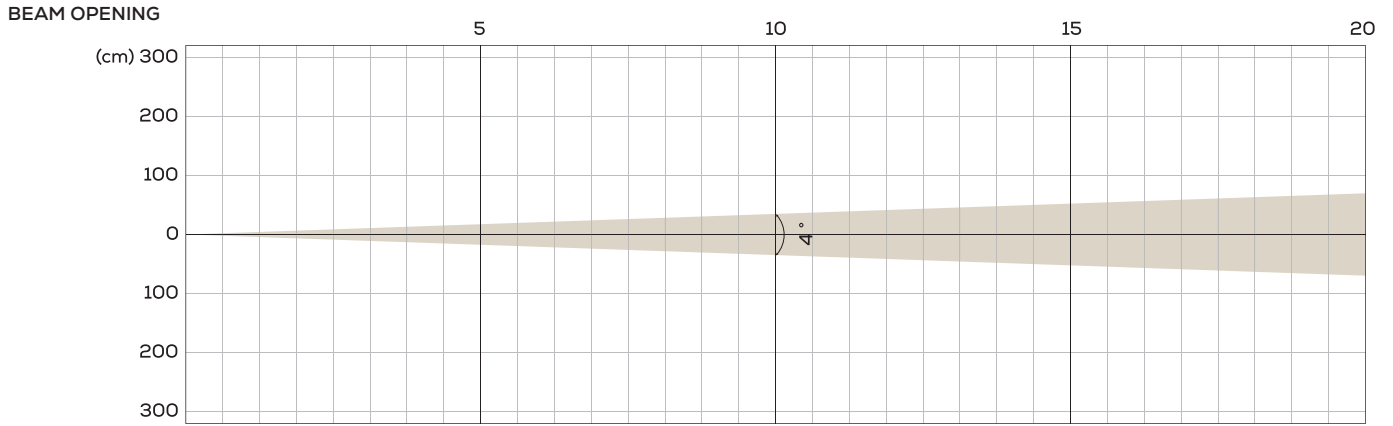

INTENSITY

Distance (m)	5		10		15		20	
	unit	Diameter	Lux	Diameter	Lux	Diameter	Lux	Diameter
White	98,621	0.35	24,655	0.7	10,958	1.05	6.164	1,4

MIDDLE ZOOM

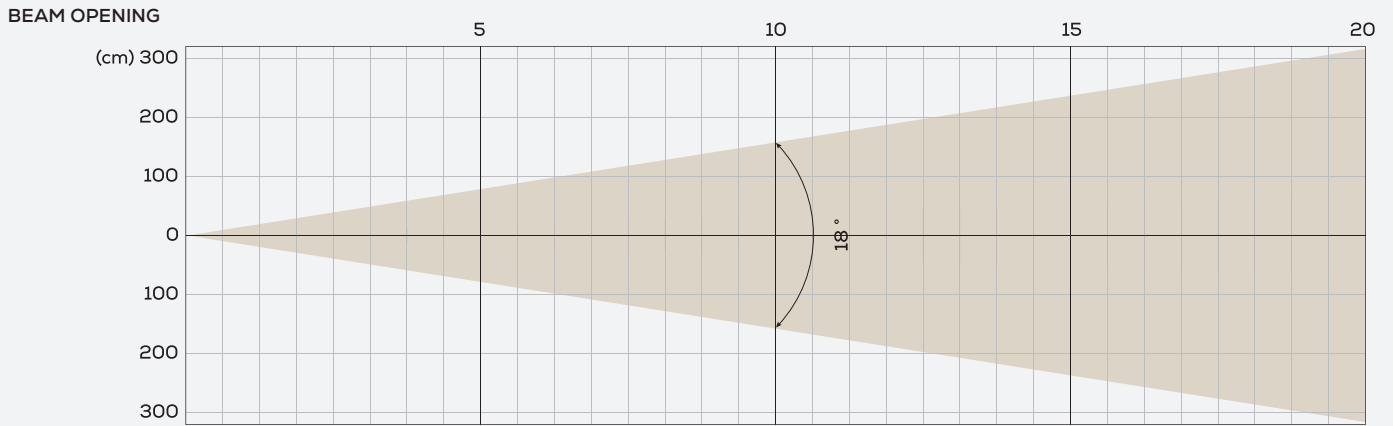

INTENSITY

Distance (m)	5		10		15		20	
	unit	Diameter	Lux	Diameter	Lux	Diameter	Lux	Diameter
White	7,672	1.58	1,918	3.17	852	4.75	480	6.34

MAX ZOOM

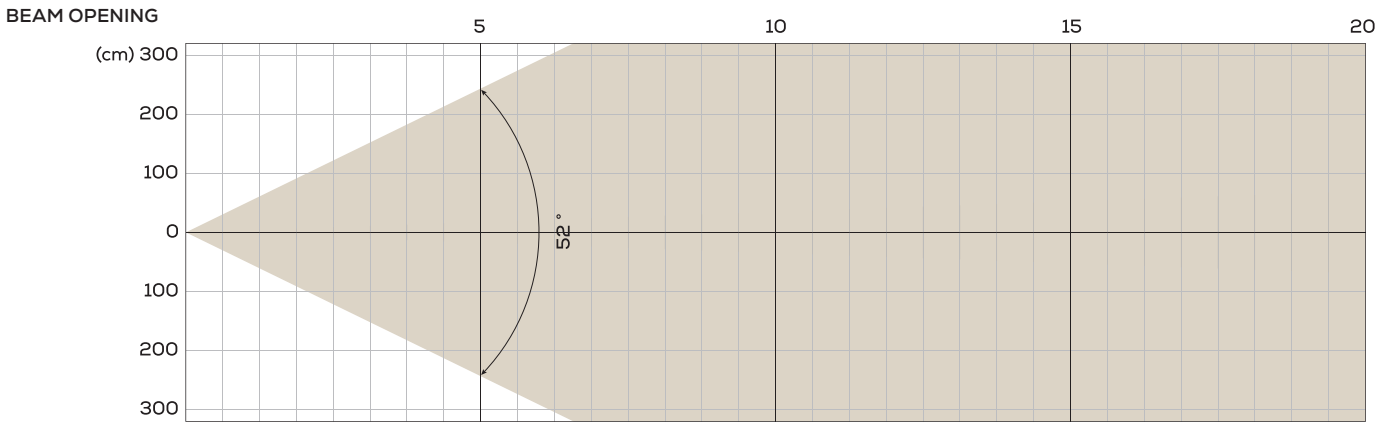

INTENSITY

Distance (m)	5		10		15		20	
	unit	Diameter	Lux	Diameter	Lux	Diameter	Lux	Diameter
White	939	4.88	235	9.75	104	14.63	59	19.51

SILENCE MODE: PHOTOMETRIC DETAIL

MIN ZOOM

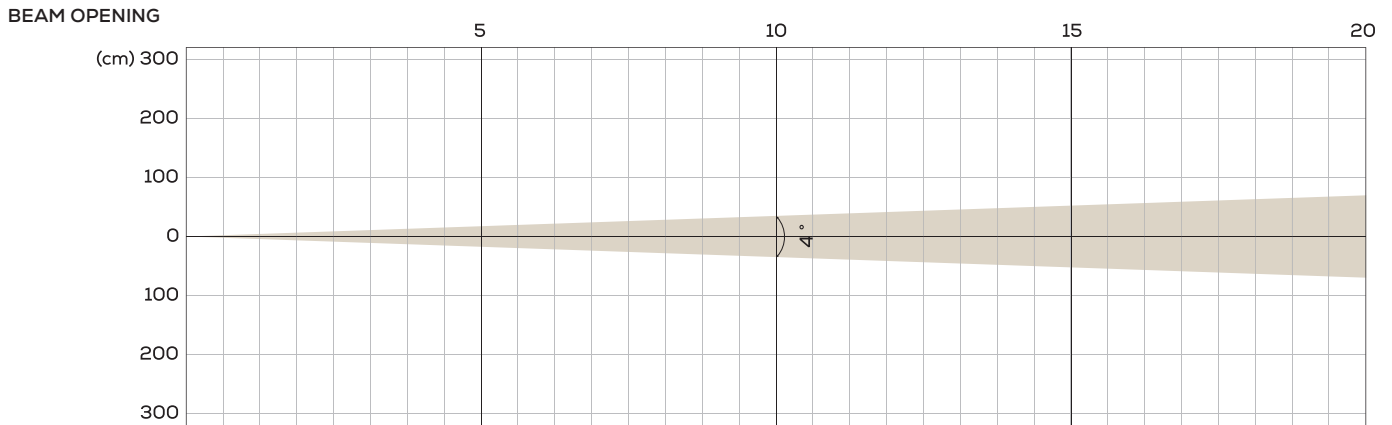

INTENSITY

Distance (m)	5		10		15		20	
	Lux	Diameter	Lux	Diameter	Lux	Diameter	Lux	Diameter
White	60,622	0.35	15,155	0.7	6,736	1.05	3,789	1.4

MIDDLE ZOOM

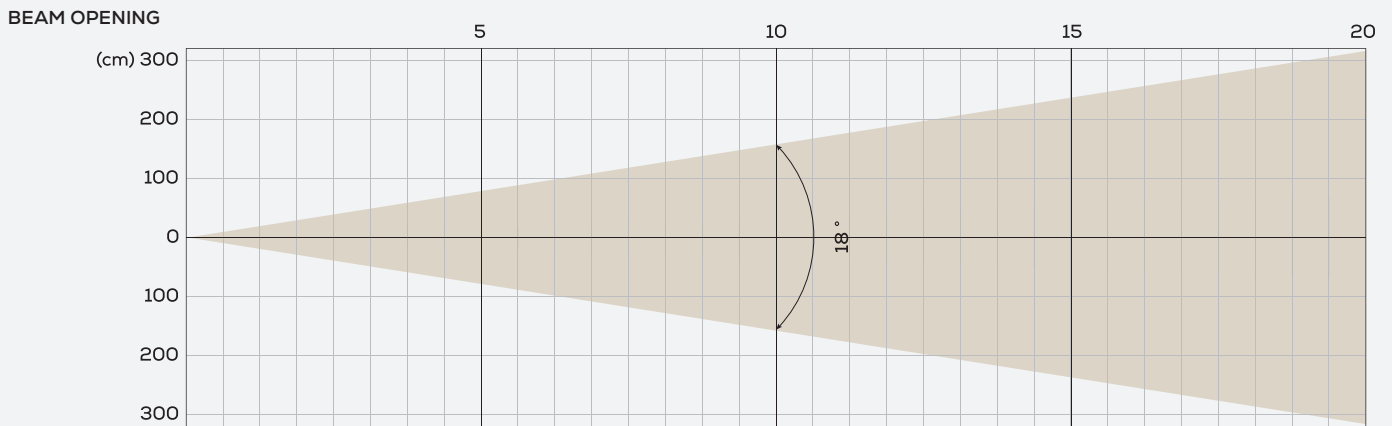

INTENSITY

Distance (m)	5		10		15		20	
	Lux	Diameter	Lux	Diameter	Lux	Diameter	Lux	Diameter
White	4,825	1.58	1,206	3.17	536	4.75	302	6.34

MAX ZOOM

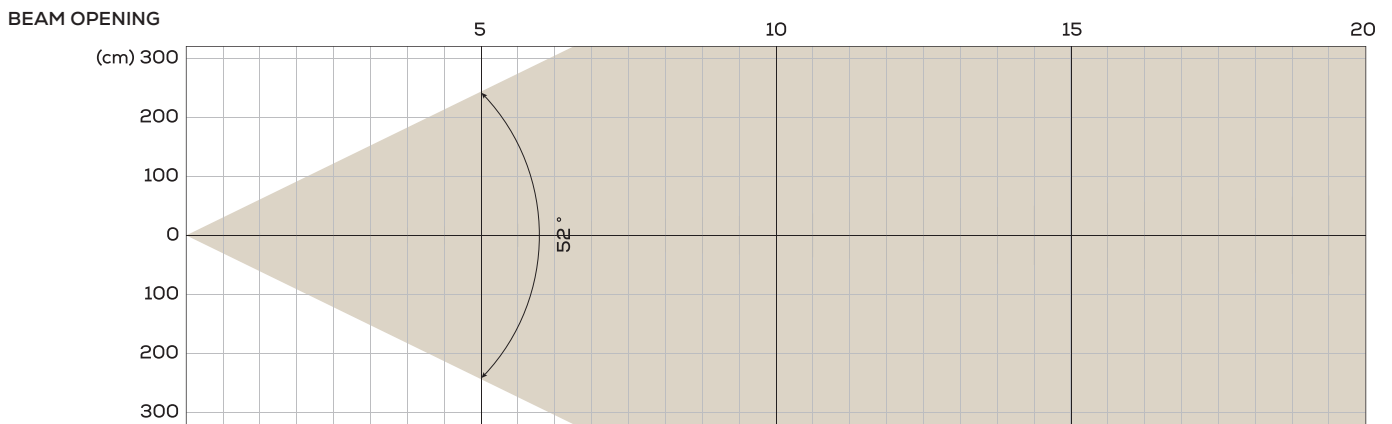

INTENSITY

Distance (m)	5		10		15		20	
	Lux	Diameter	Lux	Diameter	Lux	Diameter	Lux	Diameter
White	585	4.88	146	9.75	65	14.63	37	19.51

SUPER SILENCE MODE: PHOTOMETRIC DETAIL

MIN ZOOM

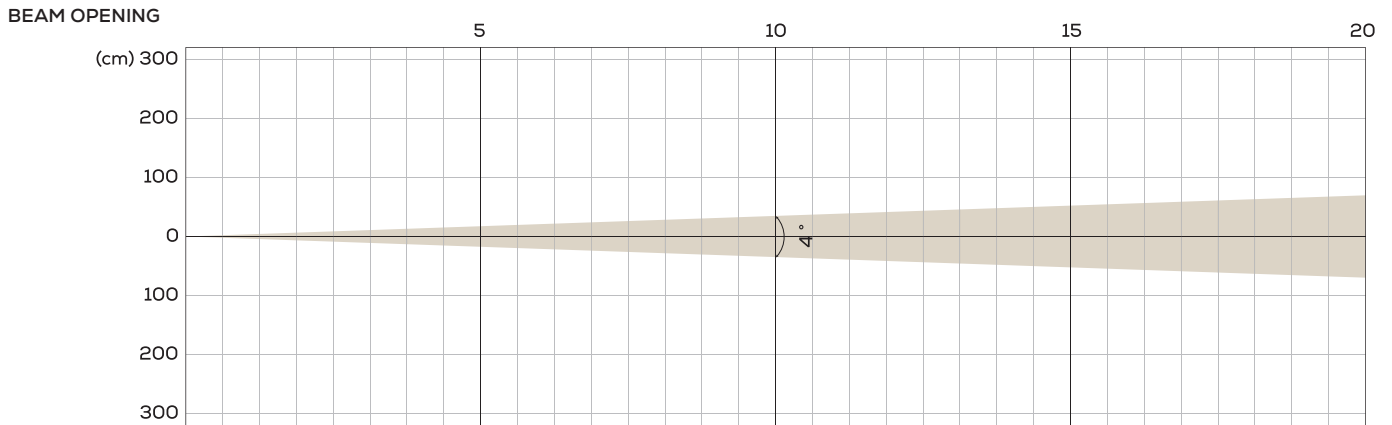

INTENSITY

Distance (m)	5		10		15		20	
	unit	Diameter	Lux	Diameter	Lux	Diameter	Lux	Diameter
White	Lux	Diameter	Lux	Diameter	Lux	Diameter	Lux	Diameter
White	50,561	0.35	12,640	0.7	5,618	1.05	3,160	1.4

MIDDLE ZOOM

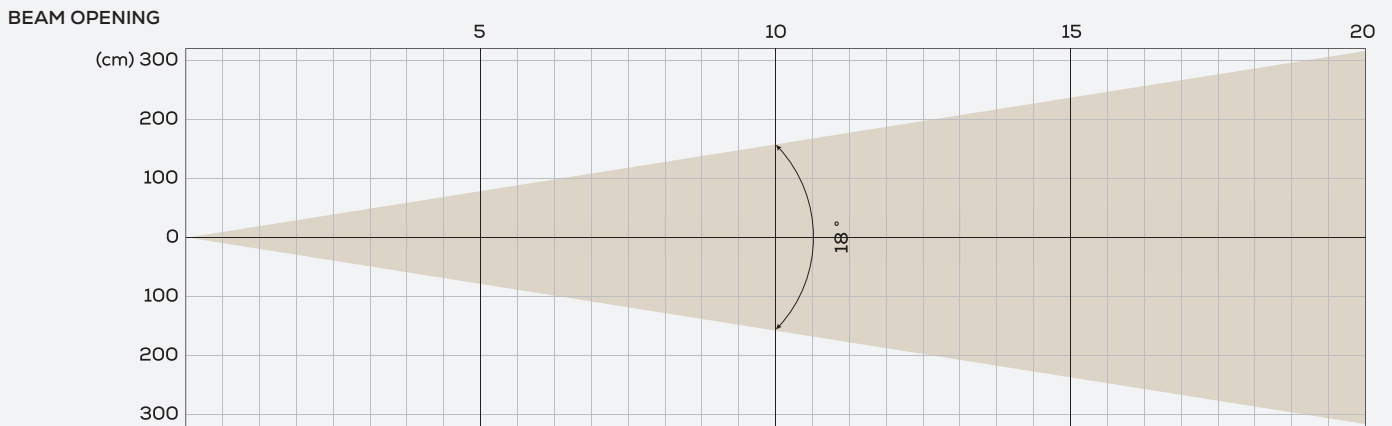

INTENSITY

Distance (m)	5		10		15		20	
	unit	Diameter	Lux	Diameter	Lux	Diameter	Lux	Diameter
White	Lux	Diameter	Lux	Diameter	Lux	Diameter	Lux	Diameter
White	7,672	1.58	1,918	3.17	852	4.75	480	6.34

MAX ZOOM

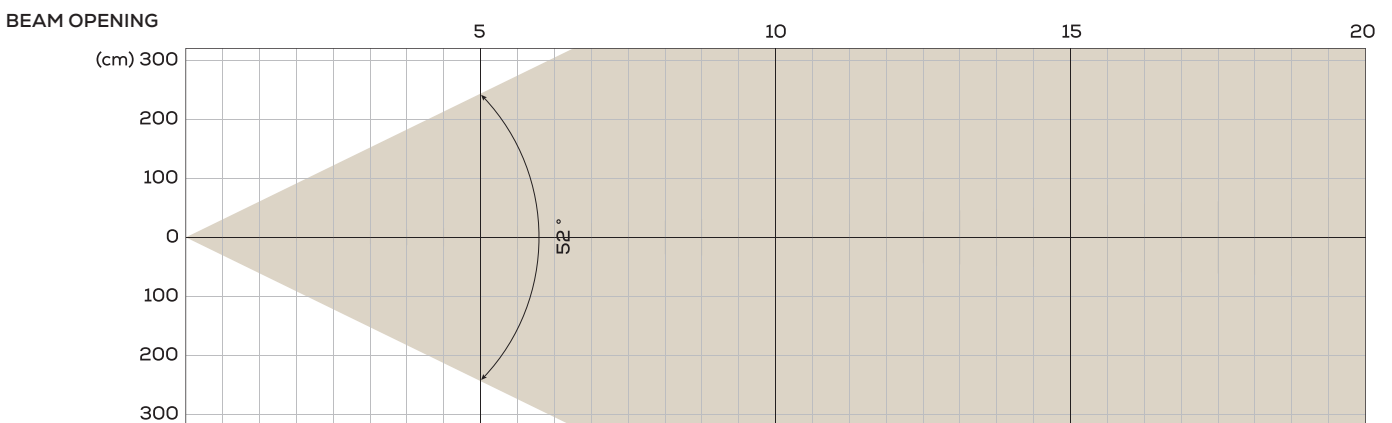

INTENSITY

Distance (m)	5		10		15		20	
	unit	Diameter	Lux	Diameter	Lux	Diameter	Lux	Diameter
White	Lux	Diameter	Lux	Diameter	Lux	Diameter	Lux	Diameter
White	939	4.88	235	9.75	104	14.63	59	19.51

COLOUR DETAILS

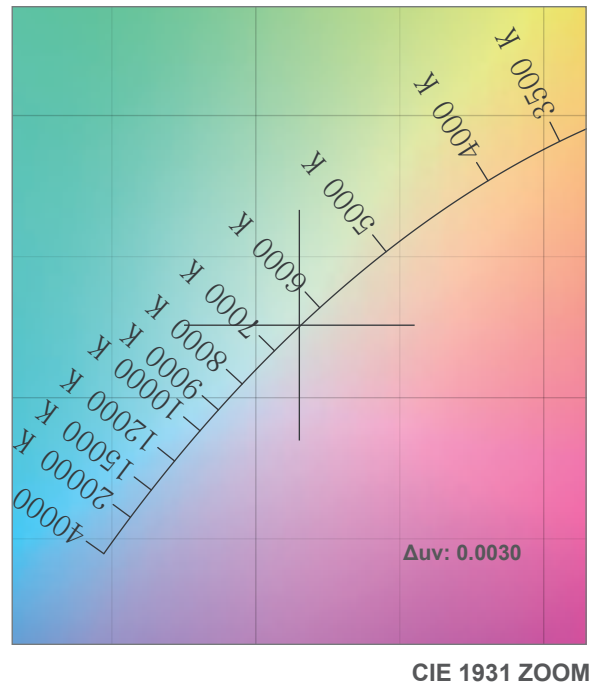
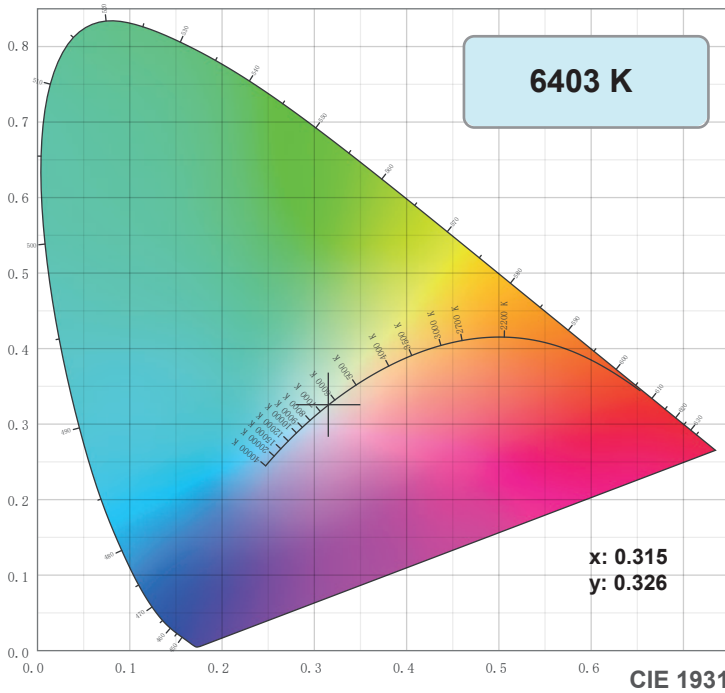

TM-30: 71.2

CRI: 71.4 (R1-R8)

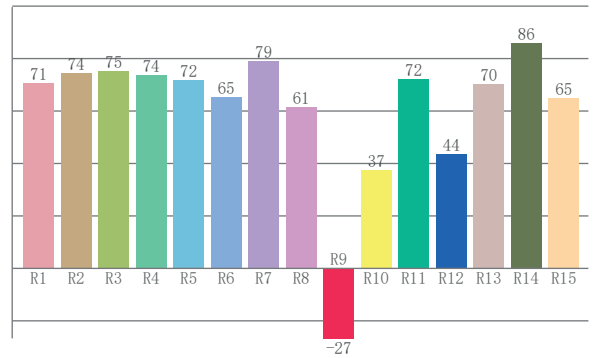
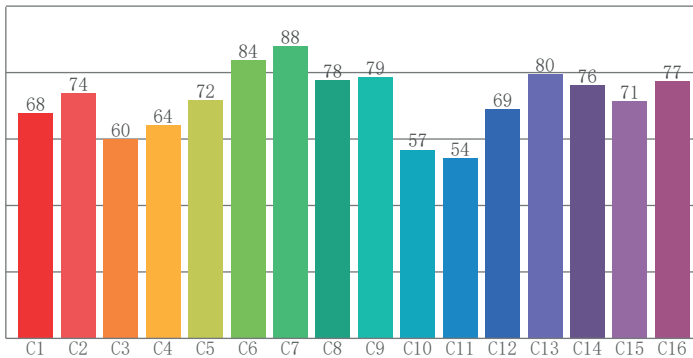

CRI R values, only R1-R8 are used to calculate final CRI value

R1	R2	R3	R4	R5	R6	R7	R8	R9	R10	R11	R12	R13	R14	R15
70.6	74.4	75.1	73.8	71.7	65.4	79.0	61.4	-26.7	37.4	72.1	43.6	70.3	85.8	65.1

TM30 C values, 16 binned values out of total of 99 C values

C1	C2	C3	C4	C5	C6	C7	C8	C9	C10	C11	C12	C13	C14	C15	C16
67.7	73.8	60.0	64.1	71.7	83.6	88.0	77.8	78.7	56.8	54.1	68.9	79.5	76.3	71.4	77.4

CQS Q values

Q1	Q2	Q3	Q4	Q5	Q6	Q7	Q8	Q9	Q10	Q11	Q12	Q13	Q14	Q15
80.2	91.1	60.1	54.6	67.1	72.0	76.8	86.5	87.0	68.6	62.6	64.6	68.3	57.5	67.2

CQS: 69.0

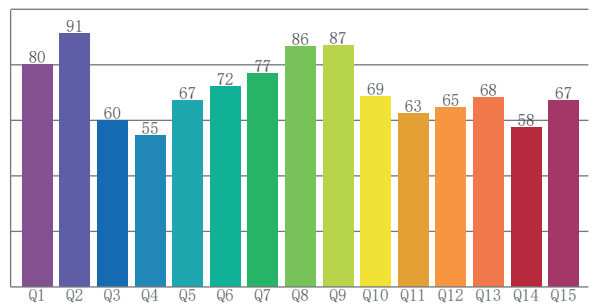

Color parameters

Color temperature	Color rendering index	Red component	Color fidelity	Color gamut	Color quality scale	Color coordinate cie 1931	Color coordinate cie 1931	Color coordinate	Color coordinate	Color deviation from black body
CCT	CRI	CRI R9	TM30 Rf	TM30 Rg	CQS	x	y	u	v	Δuv
6403 K	71.4	-26.7	71.2	94.8	69.0	0.315	0.326	0.201	0.311	0.0030

TM-30 DETAILS

Rf 71.2
Fidelity index Rf

Rg 94.8
Gamut index Rg

Hue Bin	R _f	Shifts (%)	
		Chroma	Hue
1	68	-18%	-4%
2	74	-13%	10%
3	60	-7%	23%
4	64	4%	22%
5	72	13%	13%
6	84	10%	-1%
7	88	1%	-8%
8	78	-10%	-9%
9	79	-18%	4%
10	57	-15%	22%
11	54	-4%	29%
12	69	5%	20%
13	80	14%	8%
14	76	12%	-5%
15	71	9%	-24%
16	77	-5%	-13%

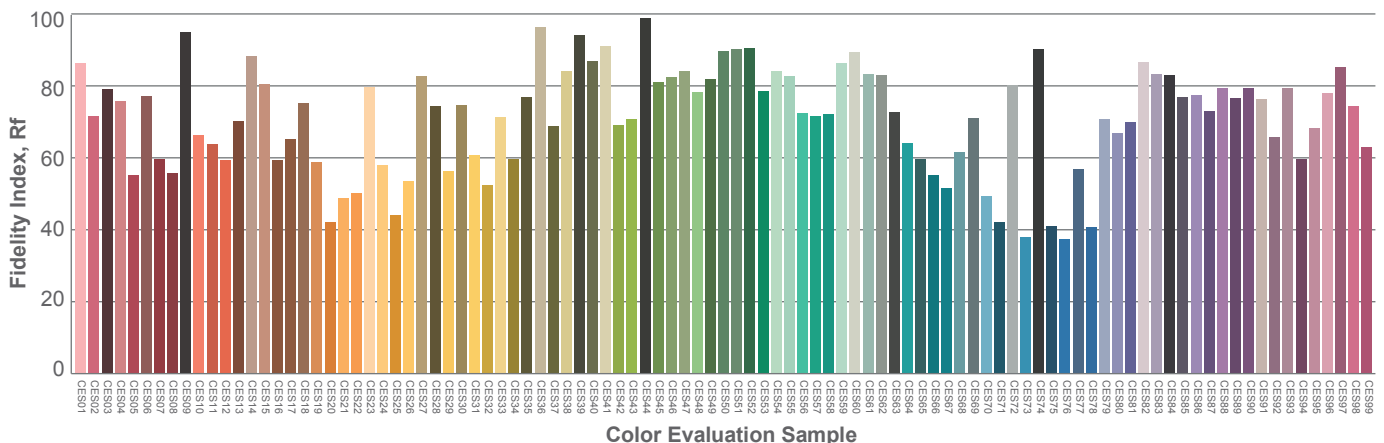
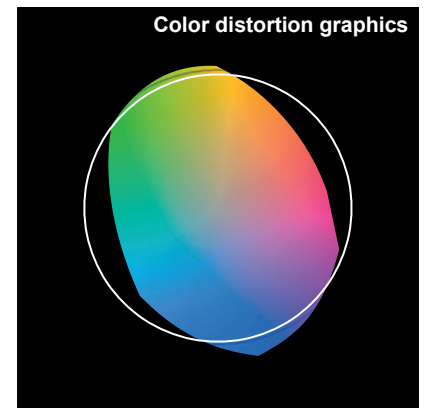
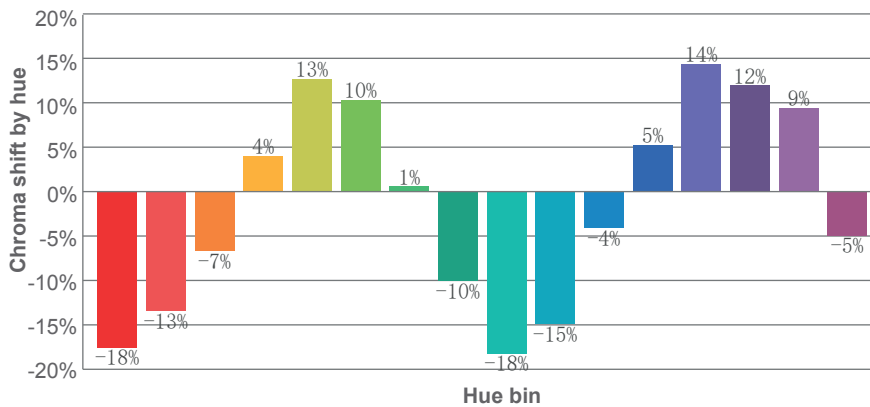
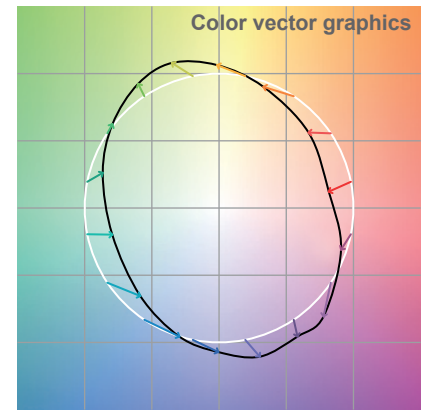
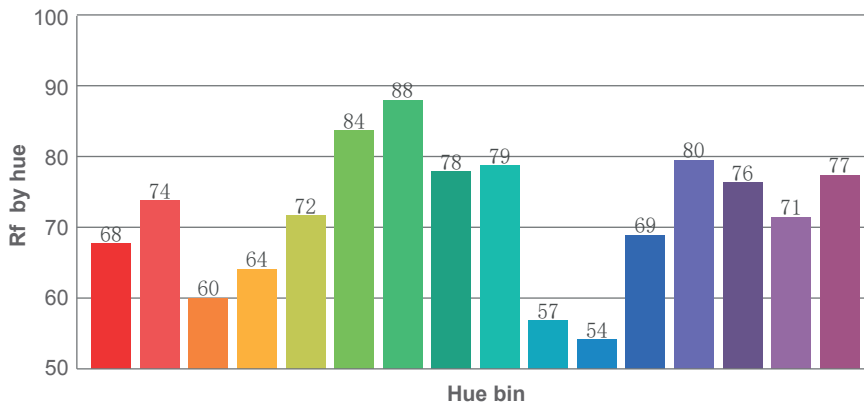
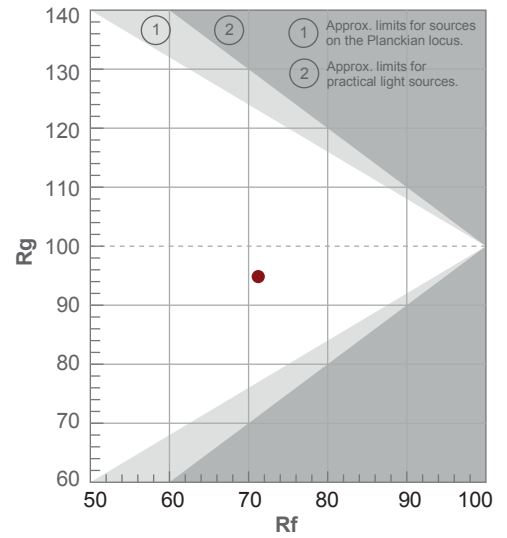

TLCI 48

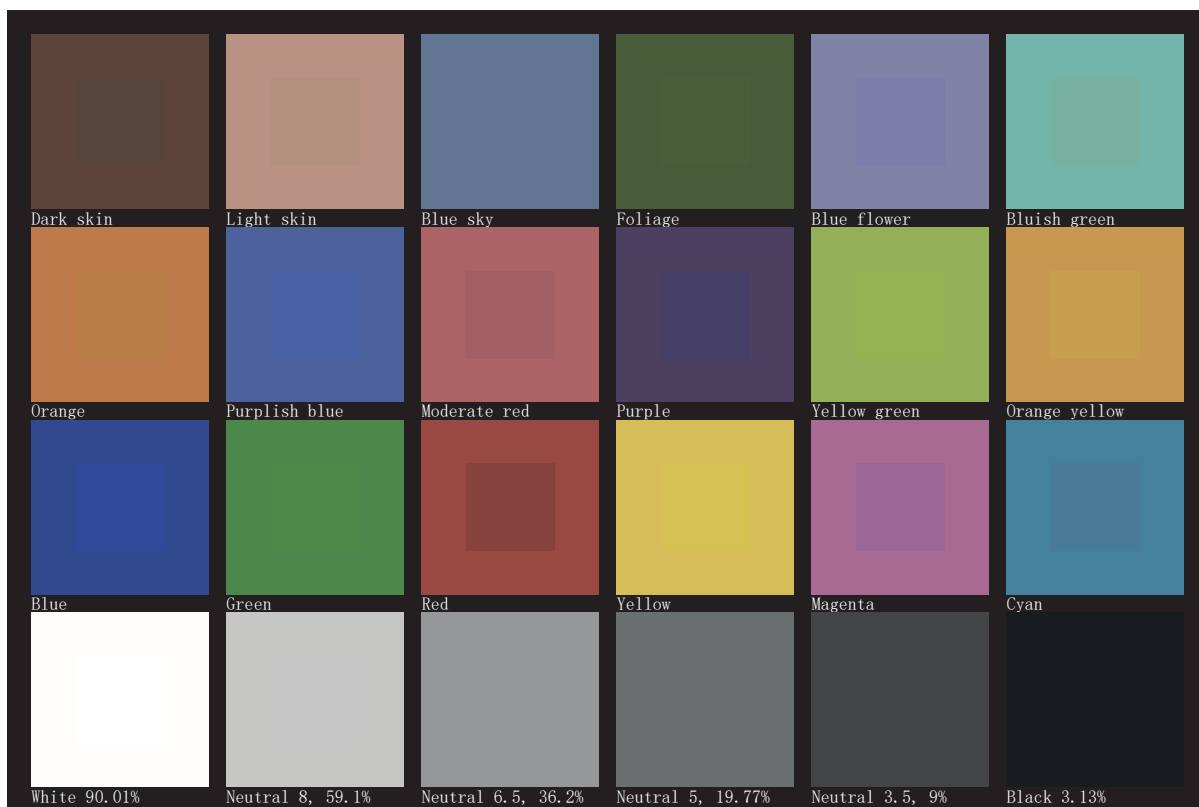

⚠️ DISCLAIMER

Errors and omissions for all information given in this specification sheet are possible. All information is subject to change without prior notice.