

**FEATURES**

- Tri-amplified VA™ 3-way full-range system
- Touring industry standard
- Stackable version without fly-track hardware; 20% weight savings
- Companion SB850zR subwoofer

**DESCRIPTION**

The KF850 Series has been the touring system standard for well over ten years, being acceptable in more technical riders than any other loudspeaker. The KF850z incorporates a number of advances in loudspeaker technology and performance developed over that time by EAW Engineers. The result is a KF850 with higher impact and fidelity than ever before.

Legendary KF850 performance is enhanced with a neodymium, Orbital Magnet Array™ HF driver offering increased surface area for better cooling, and higher reliability. A new HF horn extends HF response and fidelity while minimizing throat distortion. The critical MF subsystem is based on EAW's Radial Phase Plug™ design used in the KF650, KF750, and KF760. An optional user-installed, passive MF/HF crossover kit allows more economical, bi-amplified operation.

The KF850z's advanced performance will not be sonically compatible with existing KF850E inventories. To facilitate integration, kits are available to upgrade them to the KF850z. The KF850z's enclosure is fully compatible with the KF850E Series. However, the "z" enclosures incorporate a stacking pad on top that mates with a recess in the bottoms. KF850z DSP processor settings are available online for EAW's MX8750 as well a select group of other popular touring processors.

KF850 Series applications continue to include: concert tours, corporate events, large theaters, stadiums, cathedrals, large live music clubs. Six year warranty.

**3-WAY FULL-RANGE TRI-AMP**

See TABULAR DATA notes for details

**CONFIGURATION**

Subsystem		
	Transducer	Loading
LF	1x 15 in cone	Horn-loaded
MF	1x 10 in cone	Horn-loaded Radial Phase Plug™
HF	1x 2 in exit, 3 in voice coil neodymium compression driver	Horn-loaded

Operating Mode		
	Amplifier Channels	External Signal Processing
Tri-amp	LF, MF, HF	DSP w/3-way filters

**PERFORMANCE <sup>1</sup>**

<b>Operating Range</b>	75 Hz to 20 kHz	
<b>Nominal Beamwidth</b>		
Horz	55°	
Vert	40°	
<b>Axial Sensitivity (whole space SPL)</b>		
LF	101 dB	75 Hz to 250 kHz
MF	109 dB	250 Hz to 1050 Hz
HF	112 dB	1050 Hz to 20 kHz
<b>Peak Sensitivity (whole space SPL)</b>		
LF	106 dB	20 Hz to 20 kHz
MF	111 dB	20 Hz to 20 kHz
HF	116 dB	20 Hz to 20 kHz
<b>Input Impedance (ohms)</b>		
	<b>Nominal</b>	<b>Minimum</b>
LF	8	7.7 @ 120 Hz
MF	8	9.7 @ 1000 Hz
HF	8	9.2 @ 5010 Hz

**Recommended High Pass Filter**

High Pass =>40 Hz, 24 dB/octave

**Accelerated Life Test <sup>2</sup>**

LF	75 V	700 W @ 8 ohm
MF	56 V	400 W @ 8 ohm
HF	40 V	200 W @ 8 ohm

**Calculated Axial Output Limit (whole space SPL)**

	Average	Peak
LF	129 dB	135 dB
MF	135 dB	141 dB
HF	135 dB	141 dB

**ORDERING DATA**

Description	Part Number
KF850zR Black	0007587
<b>Optional Accessories</b>	
KF850z/SB850z caster pallet	0007683
KF850z/SB850z caster pallet kit	0008835
KF850z bi-amp crossover kit*	0007951
KF850z upgrade kit [AP6]	0006241
KF850z upgrade kit [NL8]	0006242

\* The bi-amp crossover kit can only be used on a factory-built KF850z. It cannot be used on a KF850 originally manufactured as an "E" series and later upgraded to a KF850z.

<sup>1</sup> To achieve specified performance, the listed external signal processing with EAW-provided settings is required.

<sup>2</sup> For recommendations to select power amplifier size refer to: "HOW MUCH AMPLIFIER POWER DO I NEED?" on the EAW web site.

ENCLOSURE

Material	Baltic birch plywood
Finish	Wear resistant textured black paint
Grille	Powder-coated perforated steel

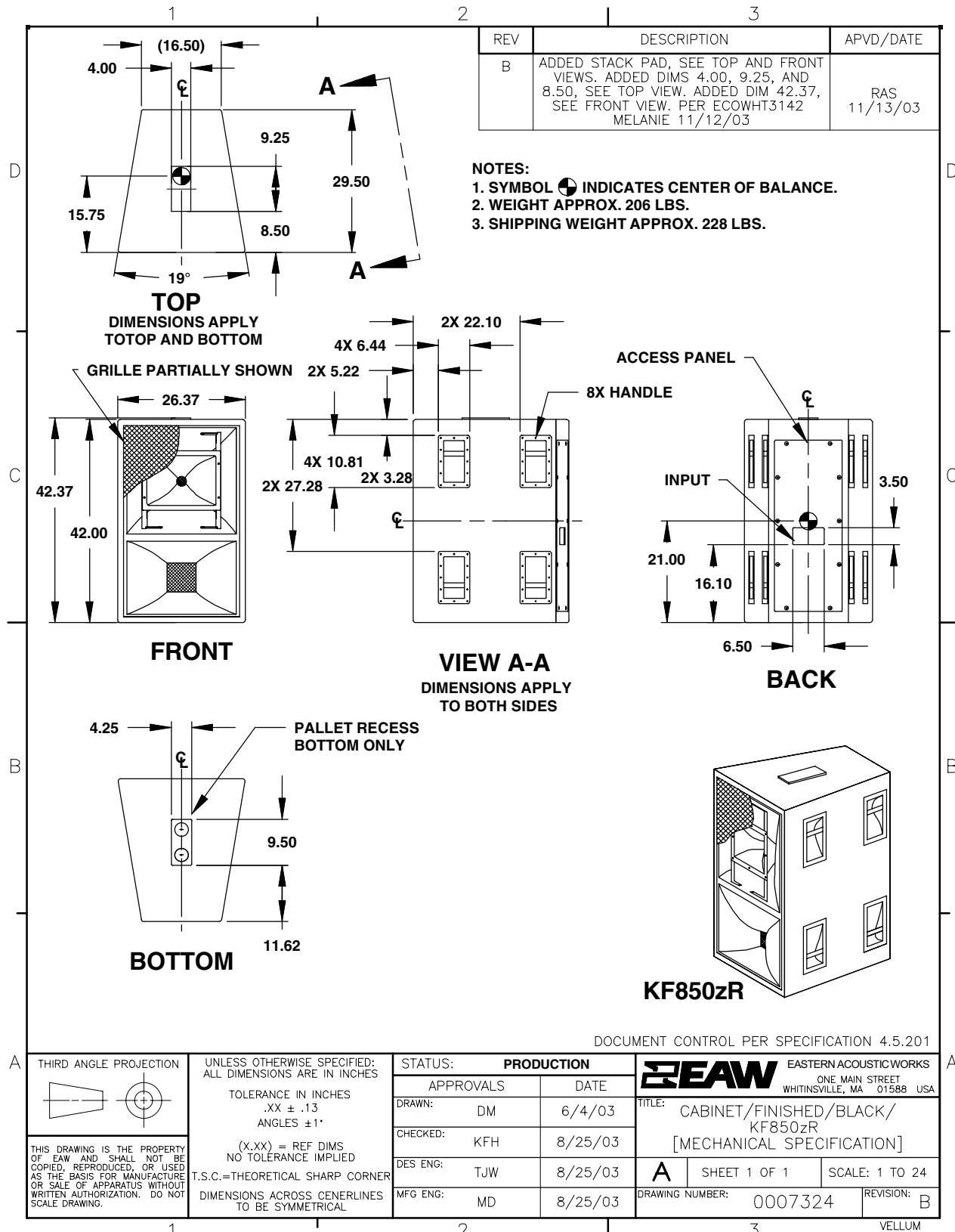

NOTE: This drawing has been reduced. Do not scale.

**PERFORMANCE DATA** See NOTES GRAPHIC DATA Notes for details

**Frequency Response: Processed Tri-amplified**

LF = green MF = Black HF = orange Complete = blue

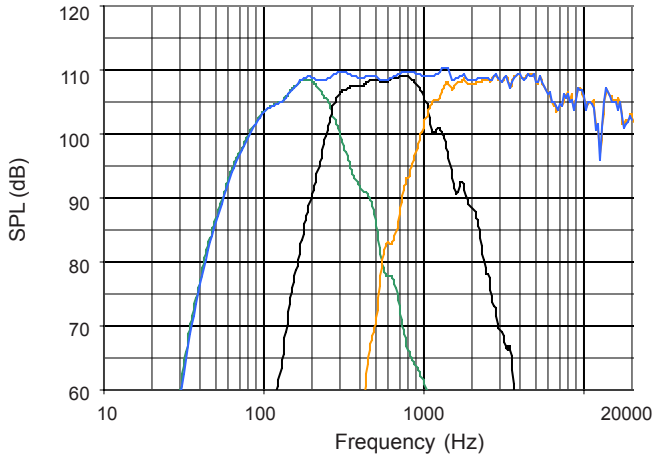

**Frequency Response: Unprocessed**

LF = green MF = Black HF = orange

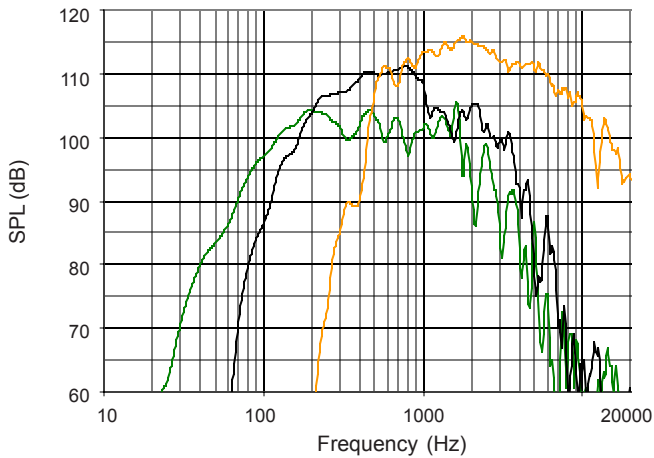

**Frequency Response: Digital Signal Processor**

LF = green MF = Black HF = orange

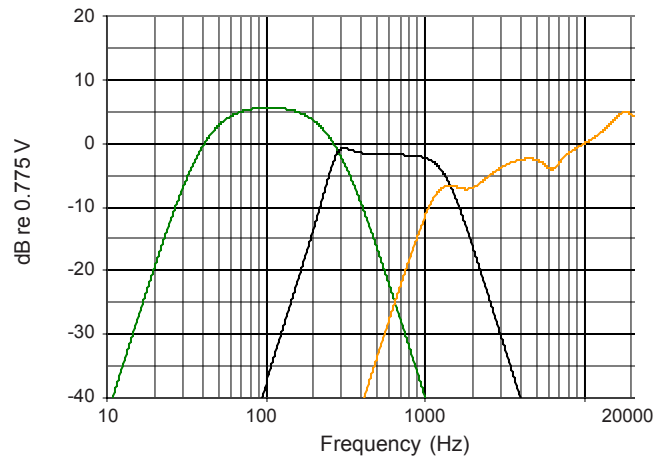

**Impedance Magnitude**

LF = green MF = Black HF = orange

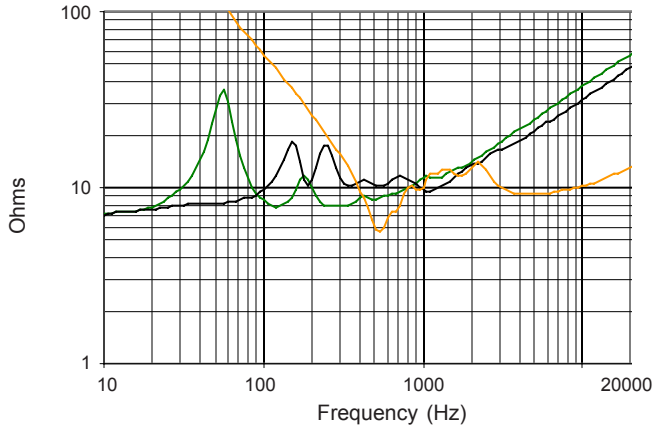

**Beamwidth (-6 dB SPL Points)**

Horizontal = orange Vertical = black

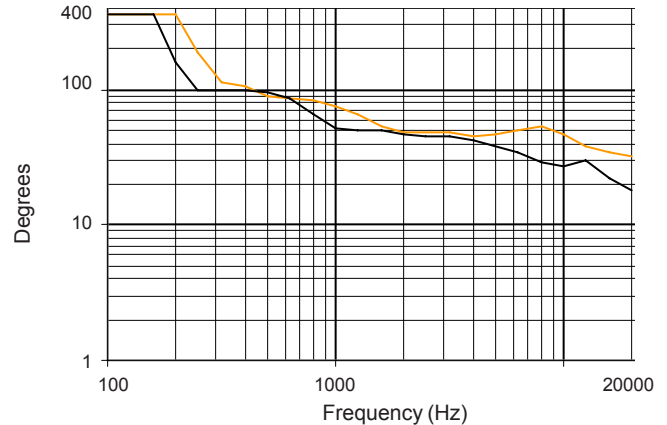

INPUT PANEL

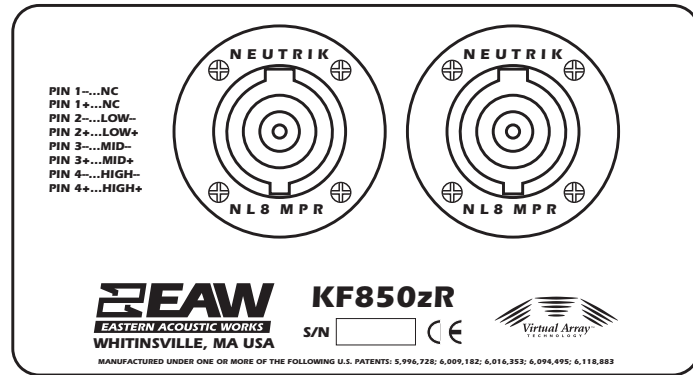

SIGNAL DIAGRAM

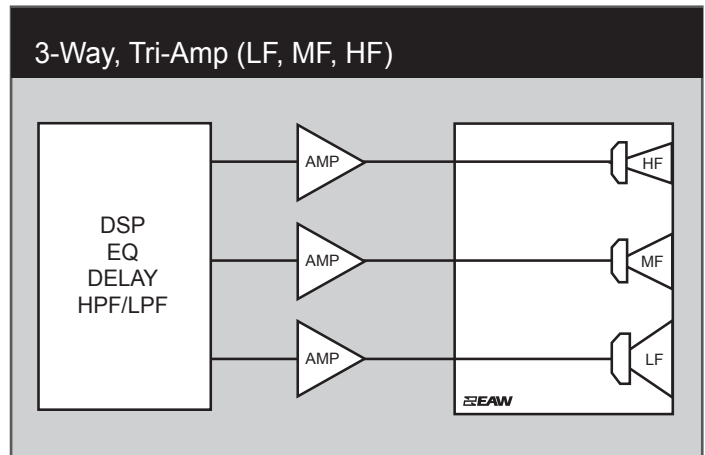

LEGEND

- DSP:** User-supplied Digital Signal Processor for EQ, crossover, and delay.
- HPF:** High Pass Filter for crossover or Recommended High Pass Filter.
- LPF:** Low Pass Filter for crossover.
- LF/MF/HF:** Low Frequency / Mid Frequency / High Frequency.
- AMP:** User-supplied Power Amplifier.
- XVR:** Passive LPFs, HPFs, and EQ integral to the loudspeaker.

NOTES

TABULAR DATA

1. **Primary Measurement/Data Processing System:** FChart: proprietary EAW software.
2. **Secondary Measurement System:** Brüel & Kjær 2012.
3. **Microphone Systems:** Earthworks M30; Brüel & Kjær 4133
4. **Measurements:** Dual channel FFT; length: 32 768 samples; sample rate: 48 kHz; logarithmic sine wave sweep.
5. **Measurement System Qualification** (includes all uncertainties): SPL: accuracy +/-0.2 dB @ 1 kHz, precision +/-0.5 dB 20 Hz to 20 kHz, resolution 0.05 dB; Frequency: accuracy +/- 1 %, precision +/-0.1 Hz, resolution the larger of 1.5 Hz or 1/48 octave; Time: accuracy +/-10.4 µs, precision +/-0.5 µs, resolution 10.4 µs; Angular: accuracy +/-1°, precision +/-0.5°, resolution 0.5°.
6. **Environment:** Measurements time-widowed and processed to eliminate room effects, approximating an anechoic environment. Data processed as anechoic or fractional space, as noted.
7. **Measurement Distance:** 7.6 to 8.0 m. Data is referenced to other distances using the Inverse Square Law.
8. **Volts:** Measured rms value of the test signal.
9. **Watts:** Per audio industry practice, "loudspeaker watts" are calculated as voltage squared divided by rated nominal impedance. Thus, these are not True Watt units of energy as defined by International Standard.
10. **SPL:** (Sound Pressure Level) Equivalent to the average level of a signal referenced to 0 dB SPL = 20 microPascals.
11. **Subsystem:** This lists the transducer(s) and their acoustic loading for each passband. Sub = Subwoofer, LF = Low Frequency, MF = Mid Frequency, HF = High Frequency.
12. **Operating Mode:** User selectable configurations. Between system elements, a comma (,) = separate amplifier channels; a slash (/) = single amplifier channel. DSP = Digital Signal Processor. IMPORTANT: To achieve the specified performance, the listed external signal processing must be used with EAW-provided settings.
13. **Operating Range:** Range where the processed Frequency Response stays within -10 dB SPL of the power averaged SPL within this range; measured on the geometric axis. Narrow band dips are excepted.
14. **Nominal Beamwidth:** Design angle for the -6 dB SPL points, referenced to 0 dB SPL as the highest level.
15. **Axial Sensitivity:** Power averaged SPL over the Operating Range with an input voltage that would produce 1 W at the nominal impedance; measured with no external processing on the geometric axis, referenced to 1 m.
16. **Peak Sensitivity:** Highest axial SPL measured within the 20 Hz to 20 kHz bandpass with an input voltage that would produce 1 W at the nominal impedance; measured with no external processing on the geometric axis, referenced to 1 m.
17. **Nominal Impedance:** Selected 4, 8, or 16 ohm resistance such that the minimum impedance point is no more than 20% below this resistance over the Operating Range.
18. **Accelerated Life Test:** Maximum test input voltage applied with an EIA-426B defined spectrum; measured with recommended signal processing and Recommended Protection Filter.
19. **Calculated Axial Output Limit:** Highest average and peak SPLs possible during the Accelerated Life Test. The Peak SPL represents the 2:1 (6 dB) crest factor of the Life Test signal.
20. **Recommended High Pass Filter:** This should be used to help protect the loudspeaker from excessive input signal levels below the Operating Range.

GRAPHIC DATA

1. **Resolution:** To remove insignificant fine details, 1/12 octave cepstral smoothing was applied to acoustic frequency response and 1/3 octave cepstral smoothing was applied to the beamwidth and impedance data. Other graphs are plotted using raw data.
2. **Frequency Responses:** The variation in acoustic output level with frequency for a constant input signal of 2 volts (4 ohm nominal impedance), 2.83 volts (8 ohm nominal impedance), or 4 volts (16 ohm nominal impedance) referenced to a distance of 1 m. For processed systems, this applies where the processor gain is 0 dB in the Processor Frequency Response graph.
3. **Processor Response:** The variation in output level with frequency for a constant input signal of 0.775 V = 0 dB reference.
4. **Beamwidth:** Average angle for each 1/3 octave frequency band where, starting from the rear of the loudspeaker, the output first reaches -6 dB SPL referenced to 0 dB SPL as the highest level. This method means the output may drop below -6 dB SPL within the beamwidth angle. Referenced to 20 m.
5. **Impedance:** Variation in impedance magnitude, in ohms, with frequency without regard to voltage/current phase. This means the impedance values may not be used to calculate True Watts (see 9 above).